

INTER-TEL HEADSET TELEPHONE USER GUIDE



INTRODUCTION

Your new headset amplifier is a device that allows you to use your telephone with a headset. It gives you hands –free, fatigue-free telephone conversation through a headset.

Please read this manual carefully, so that you can quickly learn the functions provided.

Features and Overview	3
Installation	5
Step one: Installing Batteries	
Step two: Connecting to Your Telephone	
How to Test Before Use	7
Telephone Set-up	
Compatibility Setting Between Telephone and Amplifier	
Adjustment of Listening & Transmission Volumes	
Adjustment of Dip Switch Settings	
Adjustment of Tone Control Switch	
Operation	9
Trouble Shooting	10
Warranty	11

FEATURES DIAGRAM

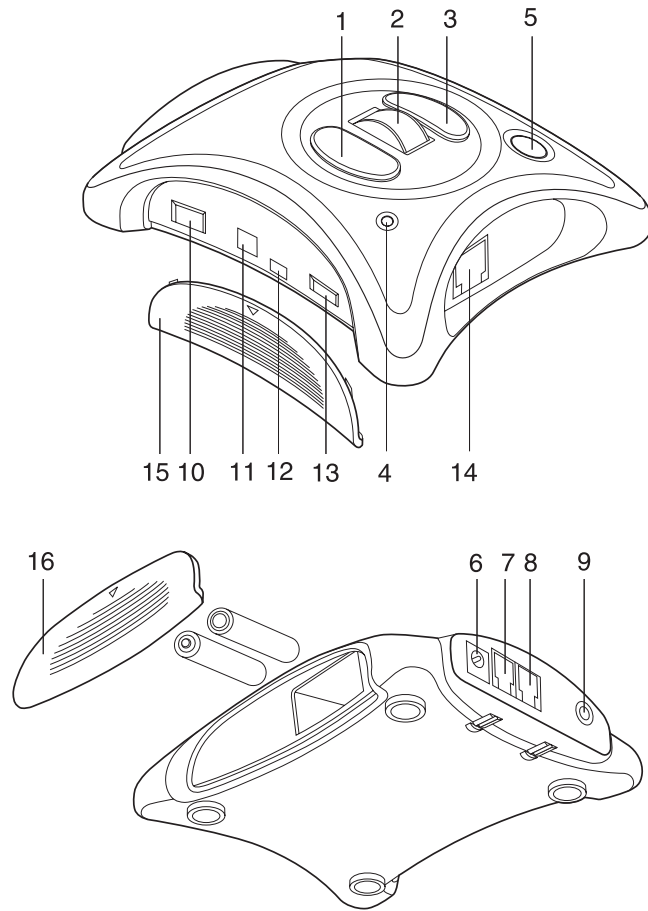

FEATURES

- 1) **Mute Switch:** Press this button to temporarily cut off your microphone transmission, then depress the button to resume communication with your caller.
- 2) **Listening Volume Control:** You can increase or decrease the volume of your caller's voice.
- 3) **Handset/Headset Button:** Press it for handset use, depress for headset use.
- 4) **Battery Test Indicator:** Press mute button, if indicator does not light up, replace all batteries.
- 5) **Tone Control:** Press to set tone to more bass or treble sound.
- 6) **External Power Supply Jack:** You may use an AC power adapter (3V DC) instead of batteries.
- 7) **Handset Jack (Handset):** Connect your telephone handset to this jack.
- 8) **Telephone Jack (Tel):** Connect the supplied short telephone cord between the handset jack of your telephone and the amplifier.
- 9) **Stereo Jack for Recorder:** This jack can be used to connect an optional recording device for recording conversations.
- 10) **Telephone Compatibility Switch:** Compatibility setting between telephone and amplifier.

FEATURES CONTINUED...

- 11) **Dip Switches:** For transmission level and dynamic microphone telephones.
- 12) **Stereo/Mono Selection Switch**
- 13) **Transmission Volume Controller:** Adjust the volume of your microphone with this control. Make a call and ask your caller how the volume of your voice sounds. Adjust accordingly.
- 14) **Headset Jack:** Connect your headset to this jack.
- 15) **Security Cover**
- 16) **Battery Cover**

INSTALLATION

Step One: Installing Batteries

We recommend two AA alkaline batteries for installation. Battery life will vary depending on use.

- 1) Remove the battery cover on the side of the amplifier.
- 2) Install two AA alkaline batteries and replace the battery cover.

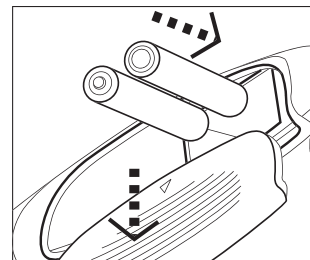

INSTALLATION CONTINUED...

- 3) Press the Mute button to confirm if batteries are properly installed. Indicator will light if unit is powered.

Note: You may also use an AC power supply in place of batteries. An optional 3V DC power supply can be connected to the external power supply jack.

Step Two: Connecting to Your Telephone and Headset

- 1) Unplug your telephone handset cord from the telephone base and plug it into the handset jack of amplifier.
- 2) Connect the supplied telephone curly cord between the handset jack of your telephone and telephone jack of the amplifier.
- 3) Plug one complete headset to the headset jack of the amplifier located on the front side of the amplifier.

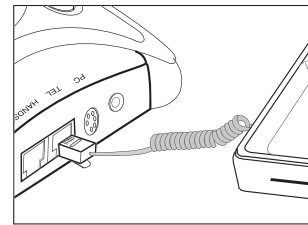
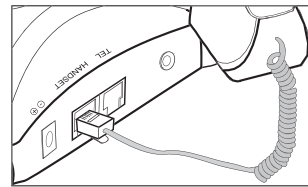
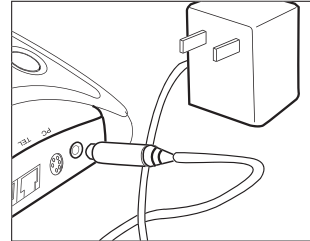

HOW TO TEST BEFORE USE

Telephone Set-up

1) Compatibility Setting Between Telephone and Amplifier

Wearing the headset, lift the handset from its cradle, position it off-hook and listen. If you can't hear dial tone at the factory setting, adjust the compatibility switch between telephone and amplifier as follows:

- A) Remove the security cover that is located on the side of the amplifier.
- B) Slide the compatibility switch by clicks until you can hear a clear dial tone.
- C) If amplifier does not work with the above actions, your handset may be a dynamic microphone. Place dip switch No. 2 to off and adjust compatibility switch again until you hear a clear dial tone.

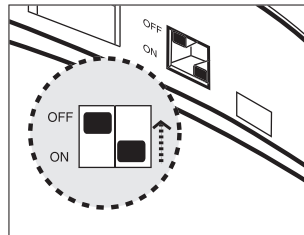
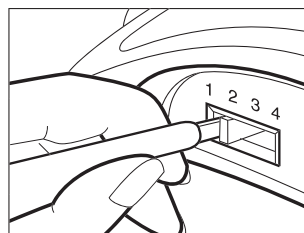
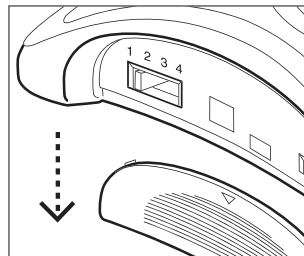

2) Adjustment of Listening Volume and Transmission Volume

Place the listening volume control to number 5 on the dial. Set the transmission volume to the center of the dial. If the unit does not sound good to you at these settings, make the following adjustments.

- A) If there is a beeping sound, slide the Transmission volume control to the right (-) to lower the volume. Other-wise, adjust the listening volume to a comfortable level for yourself. Place a call and ask your caller if your voice is at a natural volume. Adjust the transmission volume accordingly.
- B) If there is a humming tone, adjust both Listening and Transmission volume controls to lower level at the same time.
- C) If there is a high pitched feedback when the volume controls are set to normal usage levels, adjust the distance of the headset boom to one inch from the corner of your mouth.

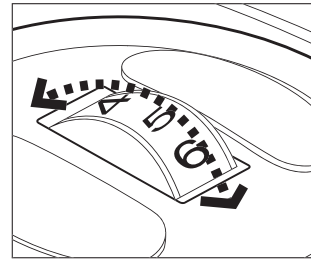
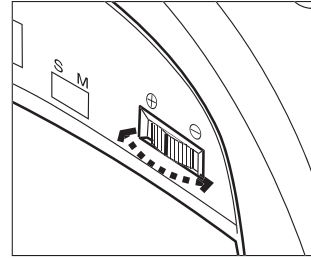

3) Adjustment of Dip Switch

If the transmission volume is too loud or too low after performing all of the above settings, it may be bad telephone line conditions or low output of telephone transmission levels.

- A) If the Transmit volume is too loud, place switch no. 1 to “off” to decrease it.
- B) If the Transmit volume is too low, please switch no. 1 to “on” to increase it.

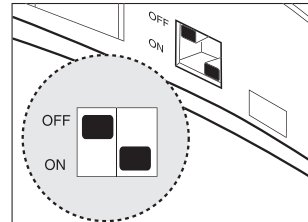

OPERATION

1) Receiving a Call By Headset

Depress the headset/handset button. Lift the handset from its cradle and place off-hook when a call comes in. The call will be received through the headset.

2) Making a Call By Headset

Wearing a headset, depress the headset/handset button, lift the handset from its cradle and place it off-hook. Dial the number after hearing dial tone. To terminate a call, hang up the telephone handset.

3) Handset Use

Press the headset/handset button, lift the handset, dial after hearing a dial tone. *Remarks: Some phone systems can be programmed to eliminate the need to lift the handset on every call. Check your phone manual for details.*

TROUBLESHOOTING

The following information covers common problems and suggests solutions:

Callers Can't Hear Me and I Can't Hear My Callers

Check the installation. Check that all cords are properly connected.

Check the Handset/Headset button. Push the button down for handset use and up for headset operation. Be sure mute button is not depressed.

Callers Voice is Low or Distorted

Adjust the listening volume control on the amplifier.

Adjust the dip switch setting according to instructions.

Replace your batteries. For best results, use good quality alkaline batteries.

Callers Can't Hear Me, but I Can Hear Them

Be sure the microphone is properly positioned, about one inch from the corner of your mouth. Check to be sure the mute button is not depressed.

Adjust the transmission volume control.

My Caller Says I Sound Unclear or Too Far Away

Adjust the position of the microphone. The best place for the microphone is not directly in front of your mouth, but near the corner of it, similar to the way you position a handset. In this position, you can pick up the sound waves from your speech, but not the air moving from your mouth and nose.

My Voice Echoes or I Sound Like I'm in a Tunnel

Slide the Transmission Volume Control to the left side for a lower volume.

WARRANTY

We will repair or replace this product, at our option, if found defective due to materials or workmanship for a period of two full years from the date of purchase. This product is warranted by authorized representative for the period specified. The original dated purchase receipt must be presented to the authorized service center when service is rendered. On all carry in models, transportation to and from the service station is the responsibility of the purchaser.

This warranty does not cover damages due to accident, fire, flood, earthquake and/or other acts of God: misuse, incorrect line voltage, improper installation, improper or unauthorized repairs, commercial use or damages occurred in shipping. Exterior and interior finish, lamps, glass, plastic parts and temperature probes are not covered under this warranty. Customer adjustment according to the owner's manual are not covered under this warranty. This warranty is automatically void if the serial number is missing or altered.

WARRANTY CARD

Mr./Mrs./Miss/Co.: _____ Phone: _____

Address _____

Model # : _____ Brand : _____

Serial # : _____ Invoice # : _____

Dealer: _____ Date of Purchase: _____

Mail to: Inter-Tel CommSource, 1016 W Geneva Drive, Tempe, AZ 85282

THIS WARRANTY CARD WILL BE VOID IF IT IS NOT MAILED BACK TO OUR COMPANY WITHIN 10 DAYS FROM DATE OF PURCHASE.

For complete product information visit our
web site at www.inter-tel.com,
select Peripheral Products and related
product categories as designated.

Inter-Tel CommSource
7300 W. Boston Street
Chandler, AZ 85226
Ph: 480-858-9600 *19765
www.inter-tel.com

 **INTER-TEL[®]**
CommSource

Peripheral Products, Applications and Services